

Product Information

S7-Panel-PLC

PC700P



(valid from PLC version PC700P-xxx-**03**)

Changes to older versions of this document

Rev. 02 → **03**: description of Profibus-signals made compatible to Siemens-manuals

Rev. 03 → **04**: new front foil, new images, new design line, connectors added

Description

Panel-PLC with TFT-color touch display

PC700P 7" TFT
(800x480 Pixel/ WVGA)

Standard configuration:

- **RS232 with**
 - free ASCII-protocol
- **RS485 with**
 - free ASCII-protocol
 - Modbus RTU
 - with switchable terminate resistors for RS485
- **Ethernet with**
 - RFC1006,
 - Send/ Receive via TCP and UDP,
 - Modbus TCP
- **CAN with**
 - protocol compatible to CANopen®
 - layer2-communication
 - with switchable terminate resistors for CAN
- **Micro-SD-slot**
 - for SD-cards up to 8 GByte

• **Run/Stop-switch**

• **Status LEDs** for Power, Battery, Error, Run

• **Inserting stripes** for Logo and identification (thereby customized adaption possible easy)

optional configuration:

- (optional)
- **Profibus DP-Master**
- **Profibus DP-Slave**
- with switchable terminate resistors for Profibus

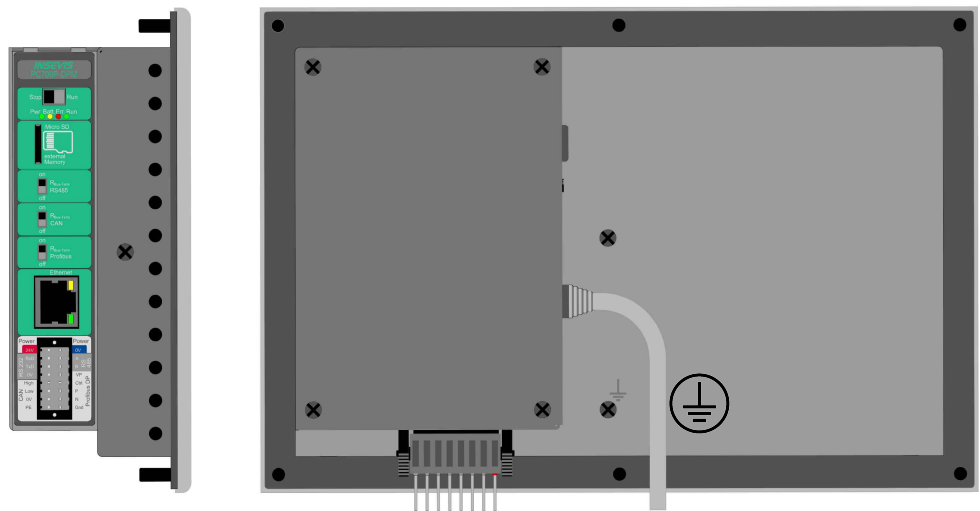

Figure above: Panel-PLCs PC700P, rear view and view from the side

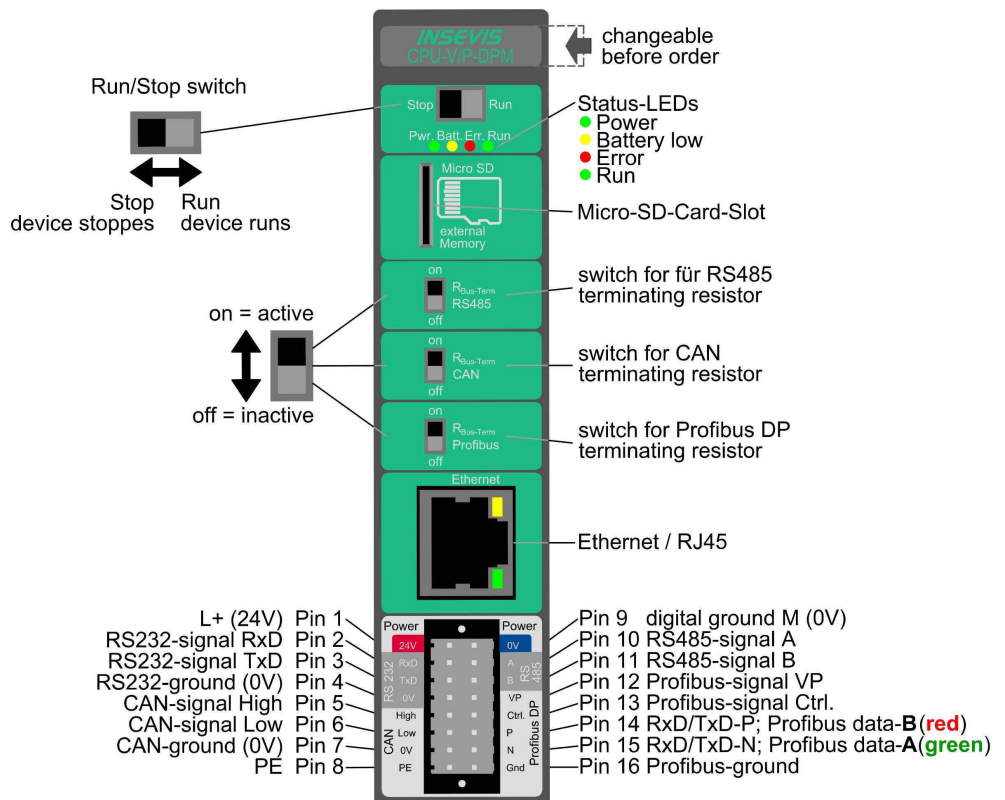

Figure above: Identification of all CPUs of all Panel-PLCs basic devices with CPU type V or P and with Profibus DP Master

Technical data	Device
Dimensions W x H x D (mm)	222 x 147 x 49
Cut out W x H (mm)	203 x 126
Weight	ca. 800 g
Operating temperature range	-20°C ... +60°C (without condensation)
Storage temperature range	-30°C ... +80°C
IP-protection class front panel	IP65
rear side	IP41
Connection technology	connector with pin-marked pushers and 2 lift-arms or 2x bolt flanges on side (cage clamp technology) for cross sections up to max. 1,5mm ²
Load voltage L+	24V DC (11 V ... 30V DC)
Current consumption	100mA ... 750mA
Power dissipation	3W(typ.) 10W(max.)
Start-up current	< 3A
Diagonal of display (inch)	7" (178mm)
Display resolution (pixel)	800x480 Pixel (WVGA)
Display unit	TFT display with 16Bit colours
Operating unit	analog resistive touch screen
Visualization software	VisuStage
Reference unit	PC700
Technical data	CPU
CPU-type	Type P (PC700P)
Working memory = battery backed load memory	640kB, thereof 384 kByte remanent data
Diagnostic buffer	100 messages (all remanent)
Flash internal for visualization	24 MByte
external memory card	Micro SD, up to max. 8 GByte (not necessary for operation)
OB, FC, FB, DB	each 1.024
Lokal data	32kByte (2kByte per block)
Number of in- and outputs	in each case 2.048 Byte (16.384 Bit) addressable
Process image	in each case 2.048 Byte (default set is 128 Byte)
Number of Merkerbytes	2.048 (remanence adjustable, default set is 0..15)
Number of Taktmerker	8 (1 Merkerbyte)
Number of timer, counter	in each case 256 (each remanence adjustable, default set is 0)
Depth of nesting	up to 16 code blocks
Real-time clock	yes (accumulator-backed hardware clock)
elapsed hour counter	1 (32Bit, resolution 1h)
Program language	STEP 7® - AWL, KOP, FUP, S7-SCL, S7-Graph from SIEMENS
Program system	SIMATIC® Manager from SIEMENS or compatible products
Operating system	compatible to S7-300® from SIEMENS
Program unit to reference	CPU 315-2PN DP
Serial interfaces (protocols)	COM1: RS 232 (free ASCII) COM2: RS 485 (free ASCII, Modbus-RTU)
Ethernet (protocols)	Ethernet: 10/100 Mbit with CP343 functionality (RFC1006, TCP, UDP, Modbus-TCP)
CAN (protocols)	CAN-Telegrams (Layer 2), compatible to CANopen® MasterSlave 10 kBaud ... 1 MBaud
Profibus (protocols)	Profibus DP V0 master/ slave 9,6kBaud ... 12 MBaud
Onboard periphery	none
Decentral periphery	- INSEVIS- Periphery (with automatic configuration via „ConfigStage“) - all CANopen® slaves according to DS401 - all Profibus DP-V0-slaves - diverse external periphery families

Control panel cut out

Dimensions

Cut out
W x H (mm) 203 x 126
6 holes with D 4,5mm

Mounting depth
ca. 49mm max.

Wiring outlet

- RJ45: in the center to the right
- connector 2x16 to the bottom
(rear view and horizontal mounting)

- RJ45: in the center down
- connector 2x16 to the left
(rear view and vertical mounting)

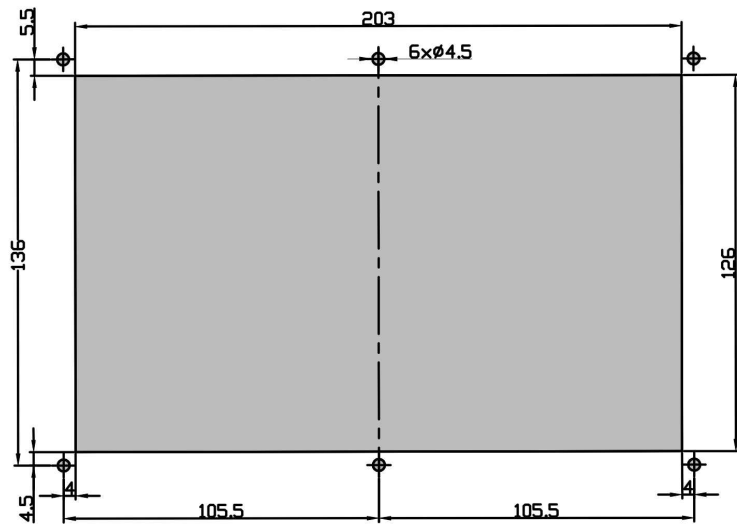

Drill jig

An 1:1 pattern as drill jig is available as PDF at INSEVIS web site for this product
Print it 1:1 and use it for marking the cut out.

Ordering data devices

Identification	Standard	with Profibus DP Master	with Profibus DP Slave
S7-Panel-PLC PC700P	PC700P-0-03	PC700P-DPM-03	PC700P-DPS-03

Ordering data accessoires

Identification / Order-No.	Identification / Order-No.
Connector 2x8pin (for PLC) / E-CON16-00	Mounting /grounding set for 5,7" / 7" -devices* / E-MNT57-00 (PU10 pcs.)
Micro SD-card 1/2/4/8GB (ext. memory) / E-MSD11/2/4/8-00	Profibus-adapter for 12MBaud-nets / E-AD-DP12
OEM-Firmware with customized logo included / SW-BS-OEM	OEM-Inserting stripe H for logo / identification for rear side (PU100 pcs.)

* (1x already part of first deliveries scope)

Qualified personnel

All devices described in this manual may only be used, built up and operated together with this documentation. Installation, initiation and operation of these devices might only be done by instructed personnel with certified skills, who can prove their ability to install and initiate electrical and mechanical devices, systems and current circuits in a generally accepted and admitted standard.

Manuals, sample programs

Additional documentation by manuals is available as well sample applications at the download area of www.insevis.com in English language for free download.

Copyright

This and all other documentation and software, supplied or hosted on INSEVIS web sites to download are copyrighted. Any duplicating of these data in any way without express approval by INSEVIS GmbH is not permitted. All property and copy rights of these documentation and software and every copy of it are reserved to INSEVIS GmbH.

Trade Marks

INSEVIS refers that all trade marks of particular companies used in own documentation are reserved trade marks are property of the particular owners and are subjected to common protection of trade marks.

Disclaimer

All technical details in this documentation were created by INSEVIS with highest diligence. Anyhow mistakes could not be excluded, so no responsibility is taken by INSEVIS for the complete correctness of this information. This documentation will reviewed regularly and necessary corrections will be done in next version. With publication of this data all other versions are no longer valid.

With publication of this information all other versions are no longer valid.